

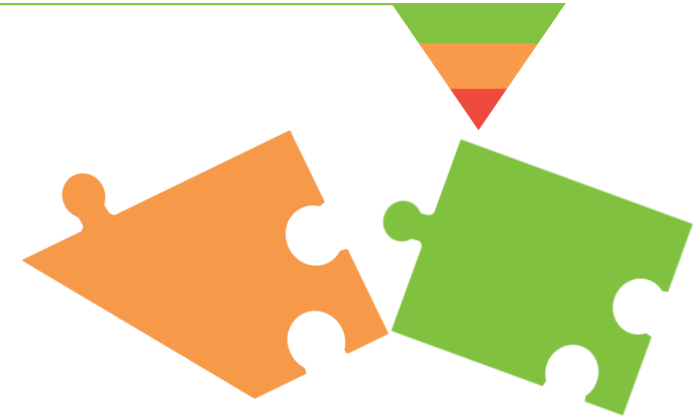

Uses of PFAS and their alternatives: applications of essentiality and functional substitution



Ian Cousins

Stockholm University, Sweden

REMTEC & EMERGING CONTAMINANTS SUMMIT,

Westminster, Colorado, US, 15th October 2024



This project has received funding from the European Union's Horizon 2020 research and innovation programme under grant agreement No 101036756.

Waste hierarchy

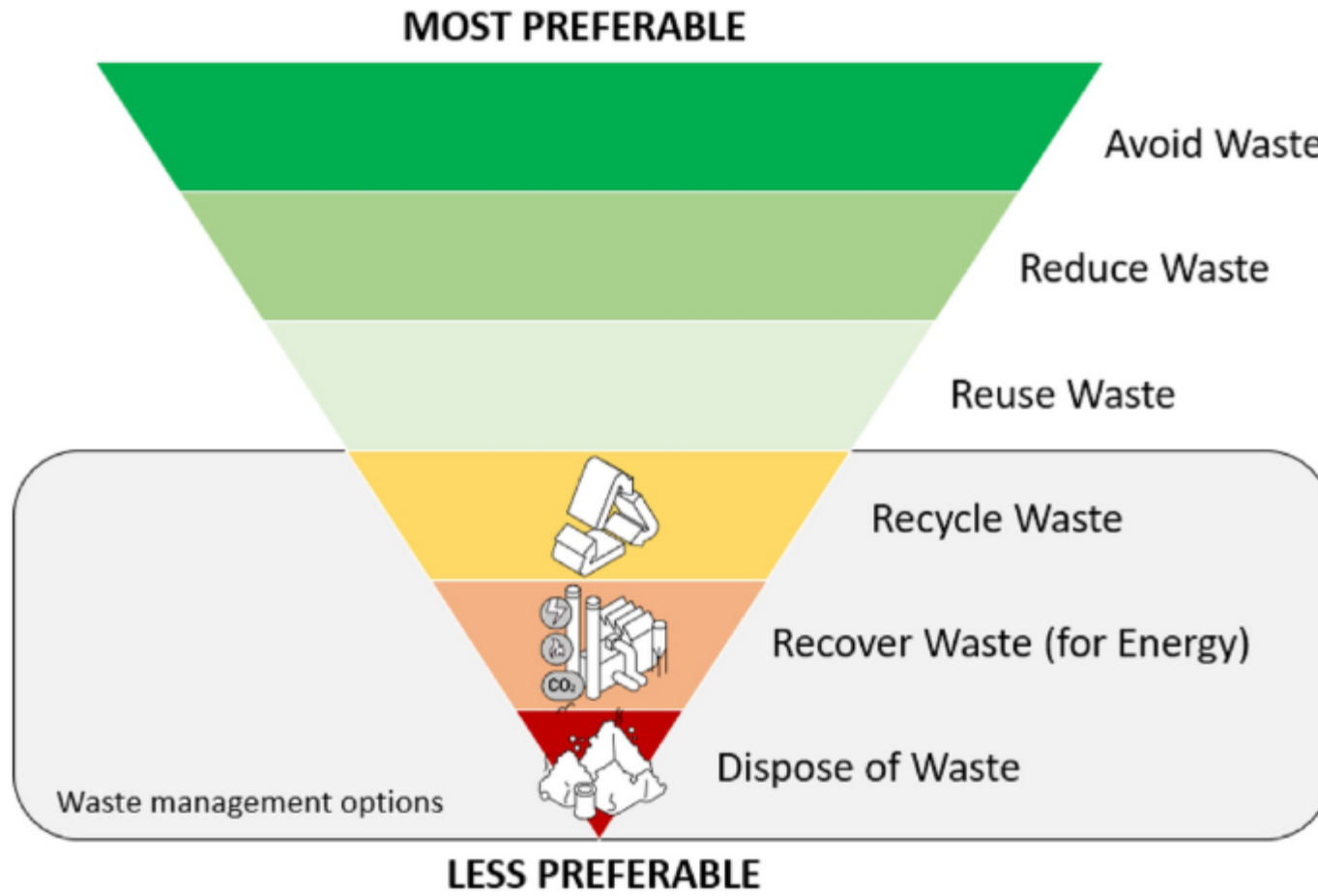

<https://zeropm.eu/>

What are PFAS?

- **Buck et al. (2011)** first definition
- **OECD (2021):** broader definition
 - "...the fluorinated substances that contain at least one fully fluorinated methyl or methylene carbon atom..."
i.e. substances are PFAS that have **at least one -CF₂- or -CF₃** moiety in their structure
 - used as regulatory definition in the EU universal restriction proposal, but if PFAS are mineralizable then they are exempted
- **US EPA (2023) definition** less broad; two connected fluorinated carbons
- Many thousands of **structurally diverse PFAS** in use in society
 - polymers & non-polymers; neutral, anionic, cationic & zwitterionic; solids, liquids & gases; reactive & inert; soluble & insoluble; volatile & involatile; mobile & immobile; bioaccumulative & non-bioaccumulative; highly toxic and relatively non-toxic

Volatile neutral PFAS

- Perfluoroalkanes (PFCs), perfluoroethers and perfluoroalkylamines

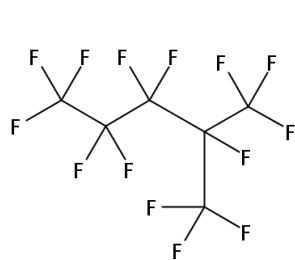

CAS No. 355-04-4

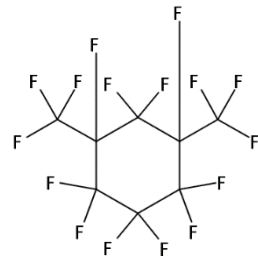

CAS No. 335-27-3

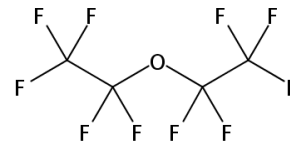

CAS No. 358-21-4

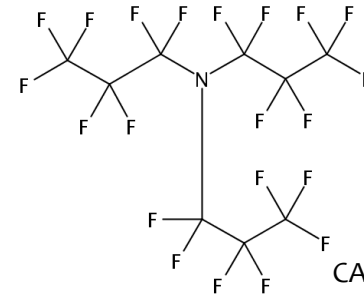

CAS No. 338-83-0

- Certain hydrofluoro-carbons (HFCs), -ethers (HFEs) and -olefins (HFOs)

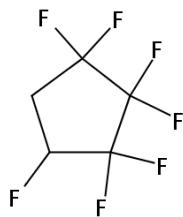

CAS No. 15290-77-4

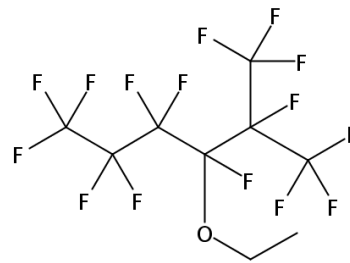

CAS No. 297730-93-9

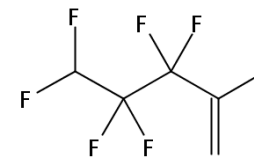

CAS No. 1547-26-8

Involatile anionic PFAS

- Per- and polyfluoroalkyl acids (PFAAs)
- Per- and polyfluoroalkylether acids

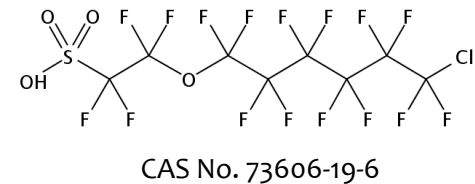
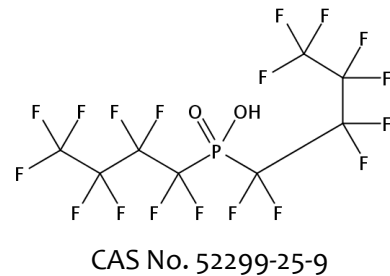
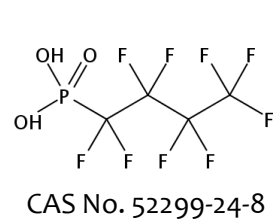
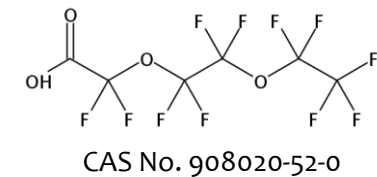
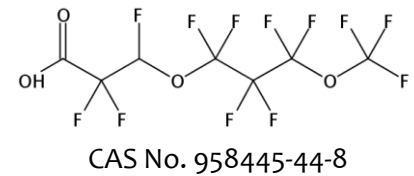
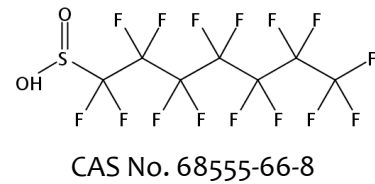
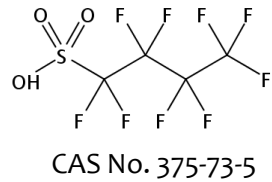
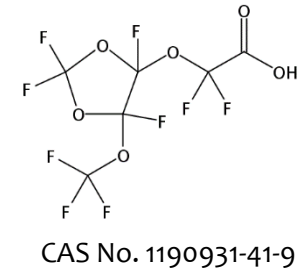
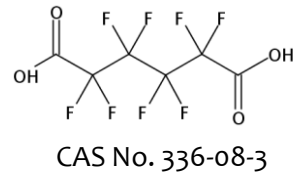
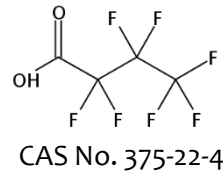

Fluorinated polymers

- Fluoropolymers (e.g. PTFE) (F in the backbone)
 - high molecular weight, stable, inert, insoluble, involatile, immobile, do not cross biological membranes, low leachables
- Side-chain fluorinated polymers (as used in textiles, carpets, food packaging)
 - non-fluorinated co-polymer backbone with fluorinated side chains
 - leachable PFAS, stable?

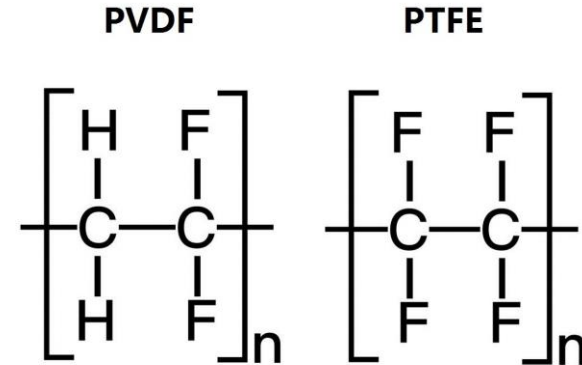

Polyvinylidene fluoride Polytetrafluoroethylene

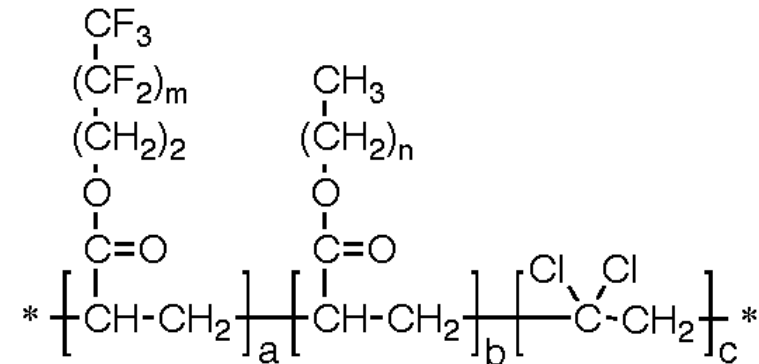

And many more: pesticides

Highly Fluorinated

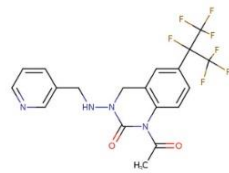

Pyriproxyfen

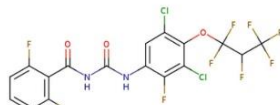

Noviflumuron

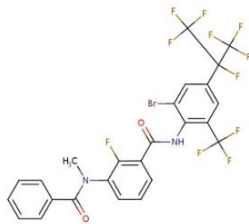

Broflanilide

Highest Use

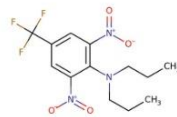

Trifluralin

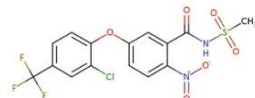

Fomesafen

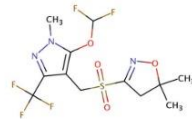

Pyroxasulfone

Known Water Contaminants

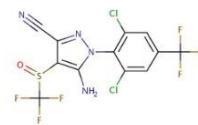

Fipronil

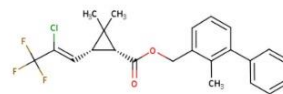

Bifenthrin

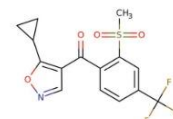

Isoxaflutole

Fluorinated Aromatics

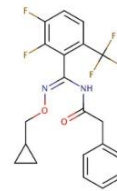

Cyflufenamid

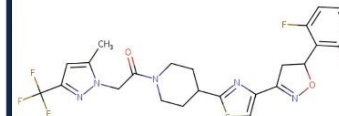

Oxathiapiprolin

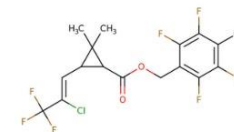

Tefluthrin

"Inert" Ingredients



1,1,1,2-Tetrafluoroethane



Polytetrafluoroethylene (PTFE)



Trans-1,3,3,3-tetrafluoroprop-1-ene

And many more: pharmaceuticals

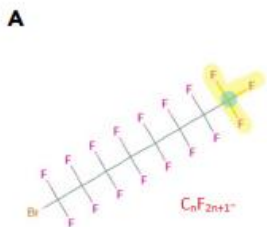

Perflubron
CAS No. 423-55-2



Enflurane
CAS No. 13838-16-9

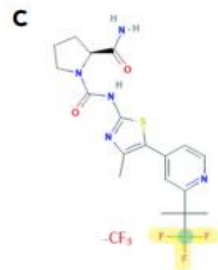

Alpelisib
CAS No. 1217486-61-7

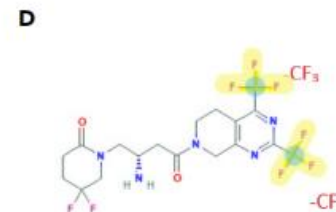

Gemigliptin
CAS No. 911637-19-9

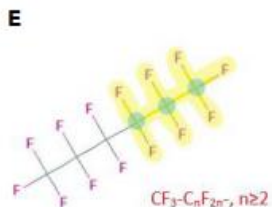

Perflexane
CAS No. 355-42-0

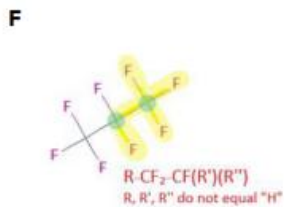

Perflutren
CAS No. 76-19-7

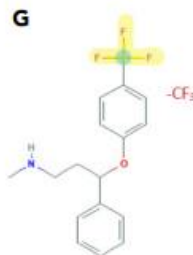

Fluoxetine (Prozac)
CAS No. 54910-89-3

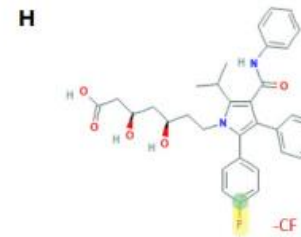

Atorvastatin (Lipitor)
CAS No. 134523-00-5

Attempt to make comprehensive overview by OECD



So how many PFAS are there? It depends on how you count...

- **>7 million** on PubChem database
 - many only listed in patents
- **4830** OECD 2018 list
- ca. **14 000** in US EPA CompTox list
- **> 10 000** in the EU PFAS Restriction Proposal
- **1 670** with identified uses
- **531** are REACH registered (>1 tonne/a)

Production volumes of PFAS

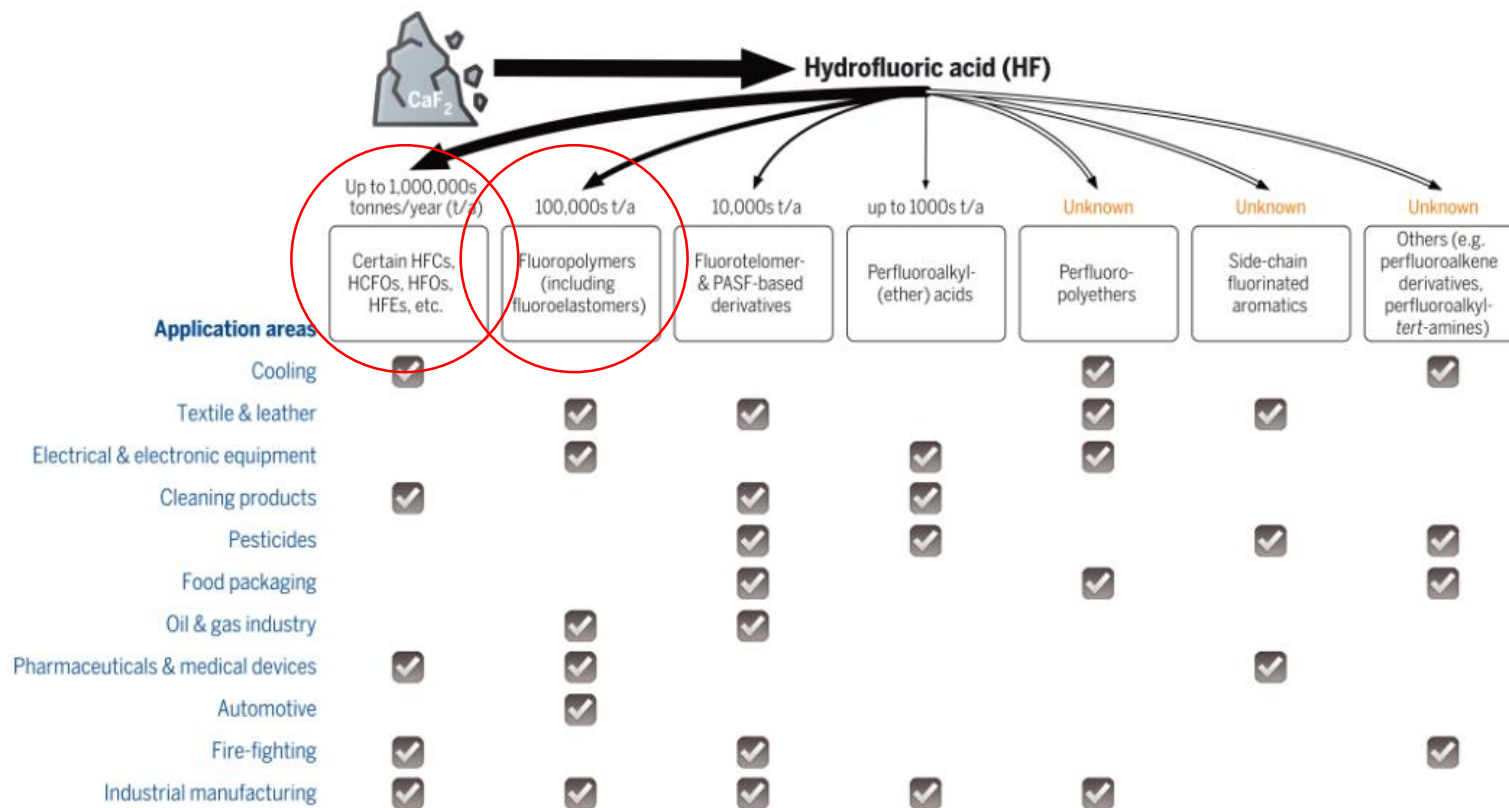

Fig. 1. Non-exhaustive summary of PFAS manufacturing, from production to consumer use.

- Industry wants most to protect uses of fluoropolymers and fluorinated gases
- Definition of PFAS changes to exclude them from PFAS definition in some US States

REVIEW SUMMARY

CHEMICAL POLLUTION

Per- and polyfluoroalkyl substances in the environment

Marina G. Evich¹; Mary J. B. Davis¹; James P. McCord¹; Brad Acrey, Jill A. Awkerman, Detlef R. U. Knappe, Andrew B. Lindstrom, Thomas F. Speth, Caroline Tebes-Stevens, Mark J. Strynar, Zhanyun Wang, Eric J. Weber, W. Matthew Henderson², John W. Washington³

Uses of PFAS

(based on information in Substances in Preparations In Nordic countries (SPIN) database)

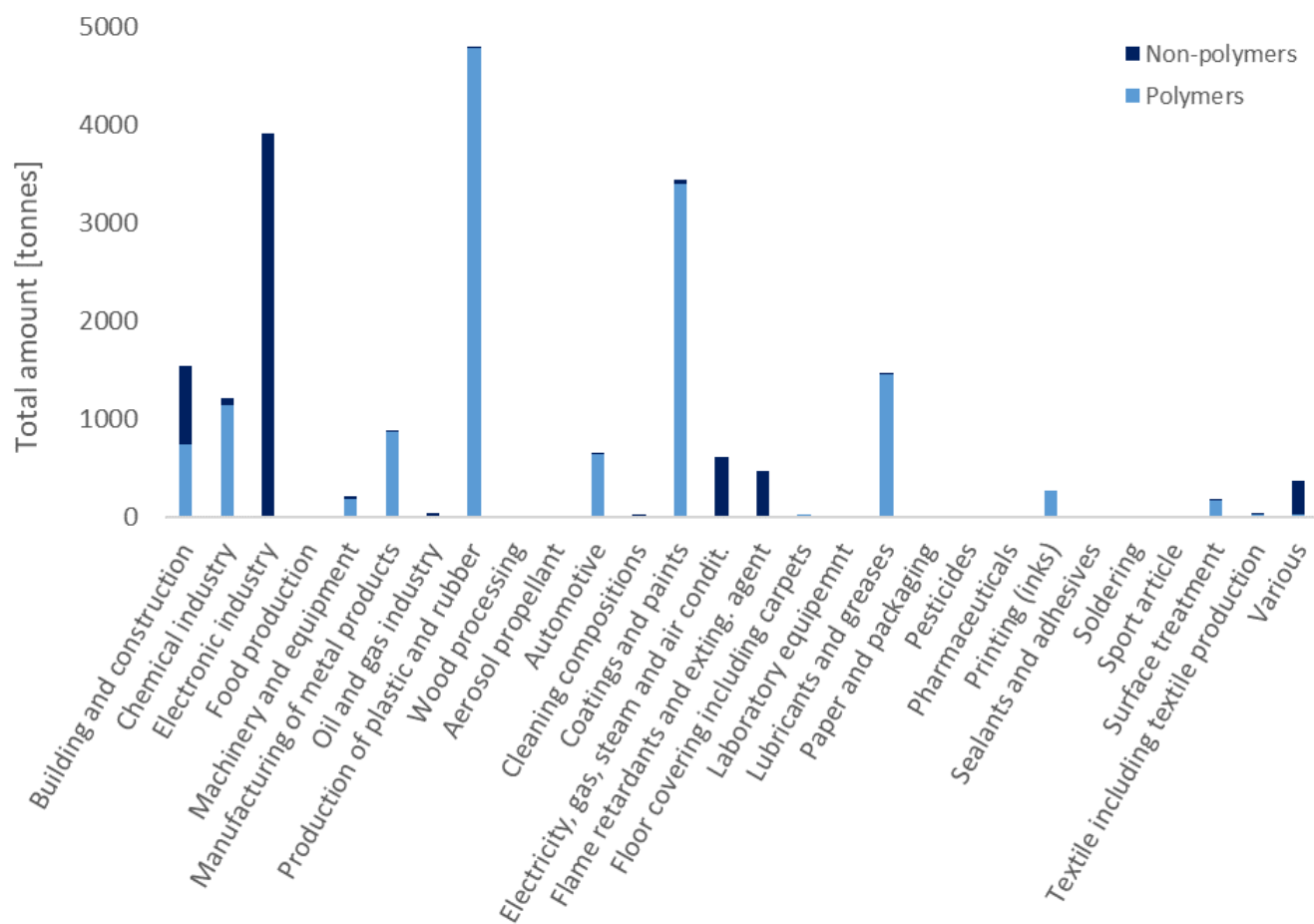

More than 200 uses identified for more than 1400 PFAS

Fluorinated polymers dominate uses

Environmental Science Processes & Impacts



PAPER

View Article Online
View Journal



An overview of the uses of per- and polyfluoroalkyl substances (PFAS)†

Cite this: DOI: 10.1039/d0em00291g

Juliane Glüge,^a Martin Scheringer,^a Ian T. Cousins,^b Jamie C. DeWitt,^c Gretta Goldenman,^d Dorte Herzke,^e Rainer Lohmann,^e Carla A. Ng,^f Xenia Trier^g and Zhanyun Wang^g

Madrid Statement

- Published in 2015
- Signed by 250 scientists from 38 countries
- Production and use of PFAS should be limited
- But are all PFAS problematic?
 - they have diverse properties, right?

Perspectives | Brief Communication

The Madrid Statement on Poly- and Perfluoroalkyl Substances (PFASs)

<http://dx.doi.org/10.1289/ehp.1509934>

Arlene Blum,^{1,2} Simona A. Balan,² Martin Scheringer,^{3,4} Xenia Trier,⁵ Gretta Goldenman,⁶ Ian T. Cousins,⁷ Miriam Diamond,⁸ Tony Fletcher,⁹ Christopher Higgins,¹⁰ Avery E. Lindeman,² Graham Peaslee,¹¹ Pim de Voogt,¹² Zhanyun Wang,⁴ and Roland Weber¹³

Regulating all PFAS?

- Authorities of Denmark, Germany, Netherlands, Norway and Sweden published a REACH restriction proposal for all PFAS meeting the OECD definition
 - Published in January 2023 and was under public consultation until 25 September 2023
 - Broad restriction based on known high persistence of all PFAS and unknown bioaccumulation potential and toxicity of most PFAS
 - 5700 comments (mostly from industry) being processed
- Separate parallel restriction proposal on PFAS in firefighting foams
 - Nearly finalized
 - 10 year phase out of PFAS in firefighting foams
- California: ban PFAS in all consumer products

Are all PFAS of concern?

- All PFAS are very persistent (vP) (EU REACH)
 - they are either non-degradable or transform into stable terminal transformation products
 - they are all extremely P with no environmental degradation observed, due to C-F bonds
- Continual release of high P chemicals results in increasing levels and increasing probabilities of known and unknown effects. Exposure poorly reversible
- They are synthetic (few natural sources), thus “novel entities”

Problems with high persistence

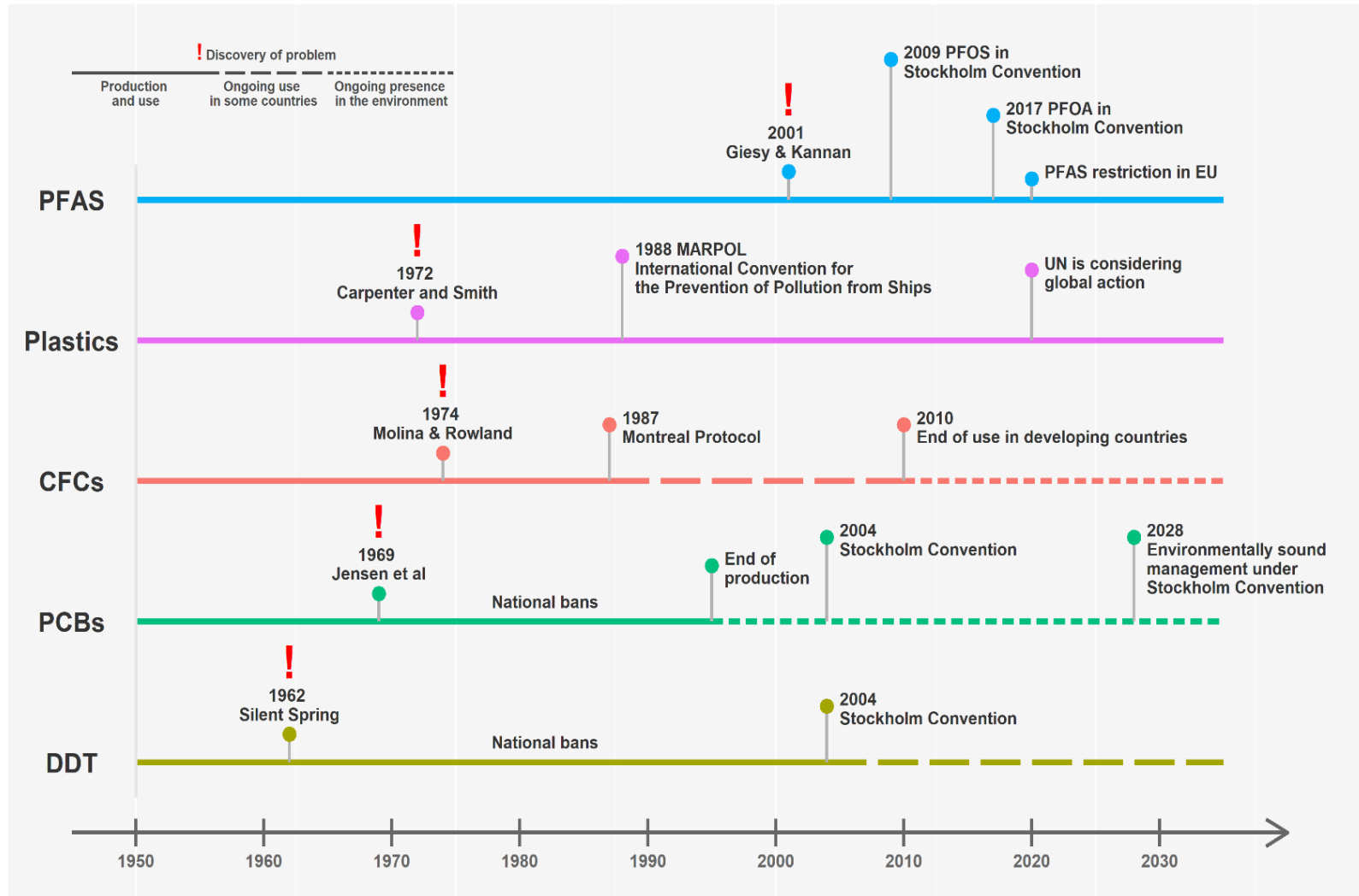

TFA the “poster child” for the problem with high persistence

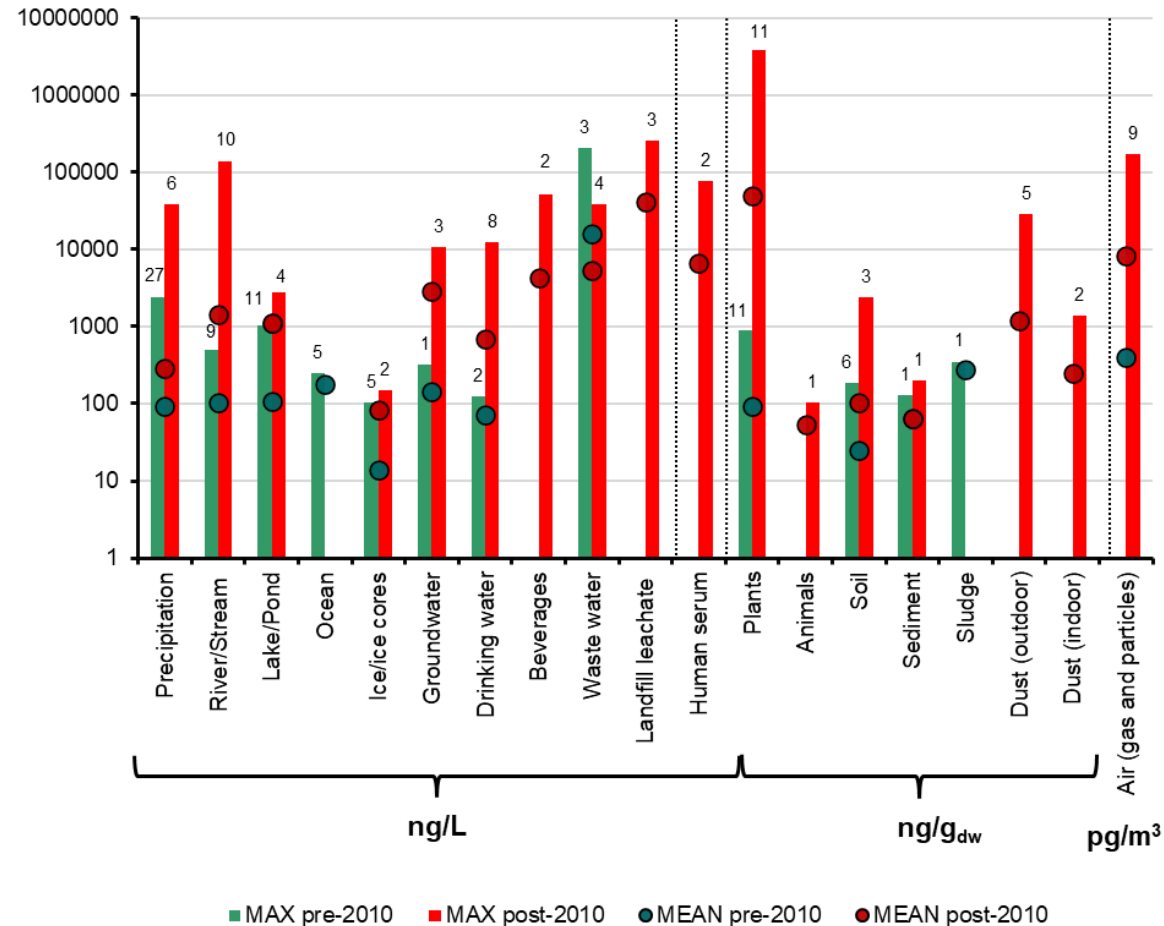

TFA concentrations in different media before 2010 (in green) and after 2010 (in red).

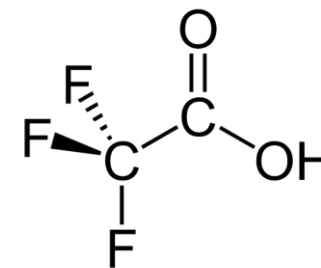

TFA – trifluoroacetic acid

Sources of TFA?

- Many “precursors”
 - refrigerants, pesticides, pharmaceuticals and other industrial chemicals
 - HFO-1234-yf, used as refrigerant, is a notable precursor
 - emissions of HFO-1234-yf projected to increase by factor of 7 between 2020 and 2050
- Destructive treatments of PFAS can also be a source of TFA (e.g. oxidation, incineration, electrolysis).
- Emissions hotspots include AFFF-contaminated sites, landfills and fluorochemical production facilities.



Are fluoropolymers a problem?

- Fluoropolymers (e.g. PTFE)
 - high molecular weight, stable, inert, insoluble, involatile, immobile, do not cross biological membranes, low leachables
- Emissions during lifecycle
 - emissions of known and unknown PFAS during manufacturing
 - emissions of low molecular weight PFAS during incineration?

Environmental
Science
Processes & Impacts



PAPER

[View Article Online](#)
[View Journal](#) | [View Issue](#)

Check for updates

Cite this: *Environ. Sci.: Processes Impacts*, 2024, 26, 269

Emission inventory of PFASs and other fluorinated organic substances for the fluoropolymer production industry in Europe†

Joost Dalmijn, *^a Juliane Glüge, ^b Martin Scheringer ^b and Ian T. Cousins *^a

Chemosphere 365 (2024) 143403



Contents lists available at ScienceDirect

Chemosphere

journal homepage: www.elsevier.com/locate/chemosphere

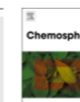

Mineralization of fluoropolymers from combustion in a pilot plant under representative European municipal and hazardous waste combustor conditions

Hans-Joachim Gehrman^{a,*}, Philip Taylor^{b,*}, Krasimir Aleksandrov^a, Philipp Bergdolt^a, Andrei Bologa^a, David Blye^c, Priyank Dalal^d, Priyanga Gunasekar^d, Sven Herremanns^e, Deepak Kapoor^d, Meg Michell^f, Vanessa Nuredin^a, Michael Schlipf^f, Dieter Stapf^a

PFAS being regulated in Europe

France 24

'Forever chemicals': French MPs approve PFAS product ban

French MPs on Thursday approved the first reading of a bill aimed at restricting the manufacture and sale of non-essential products...



Just Style

Denmark to ban PFAS in clothing, shoes from July 2026

As part of a new PFAS action plan Denmark's government has proposed to introduce a national ban on PFAS in clothing and shoes.



Pinsent Masons

New UK PFAS restrictions closer as debate over alternatives intensifies

Manufacturers could face restrictions on using per- and polyfluoroalkyl substances (PFAS) – so-called 'forever chemicals' – to make cleaning...



ECHA
EUROPEAN CHEMICALS AGENCY

ANNEX XV RESTRICTION REPORT

PROPOSAL FOR A RESTRICTION

SUBSTANCE NAME(S): Per- and polyfluoroalkyl substances (PFASs)

IUPAC NAME(S): n.a.

EC NUMBER(S): n.a.

CAS NUMBER(S): n.a.

CONTACT DETAILS OF THE DOSSIER SUBMITTERS:

BAuA
Federal Institute for Occupational Safety and Health
Division 5 - Federal Office for Chemicals
Friedrich-Henkel-Weg 1-25
D-44149 Dortmund, Germany

Bureau REACH, National Institute for Public Health and the Environment (RIVM)
Antonie van Leeuwenhoeklaan 9
3721 MA Bilthoven, The Netherlands

Swedish Chemicals Agency (KEMI)
PO Box 2,
SE-172 13 Sundbyberg, Sweden

Norwegian Environment Agency
P.O. Box 5672 Torgarden
N-7485 Trondheim, Norway

The Danish Environmental Protection Agency
Tolderundsvej 5
5000 Odense C, Denmark

VERSION NUMBER: 2

DATE: 22.03.2023

Drivers to phase out PFAS and find alternatives

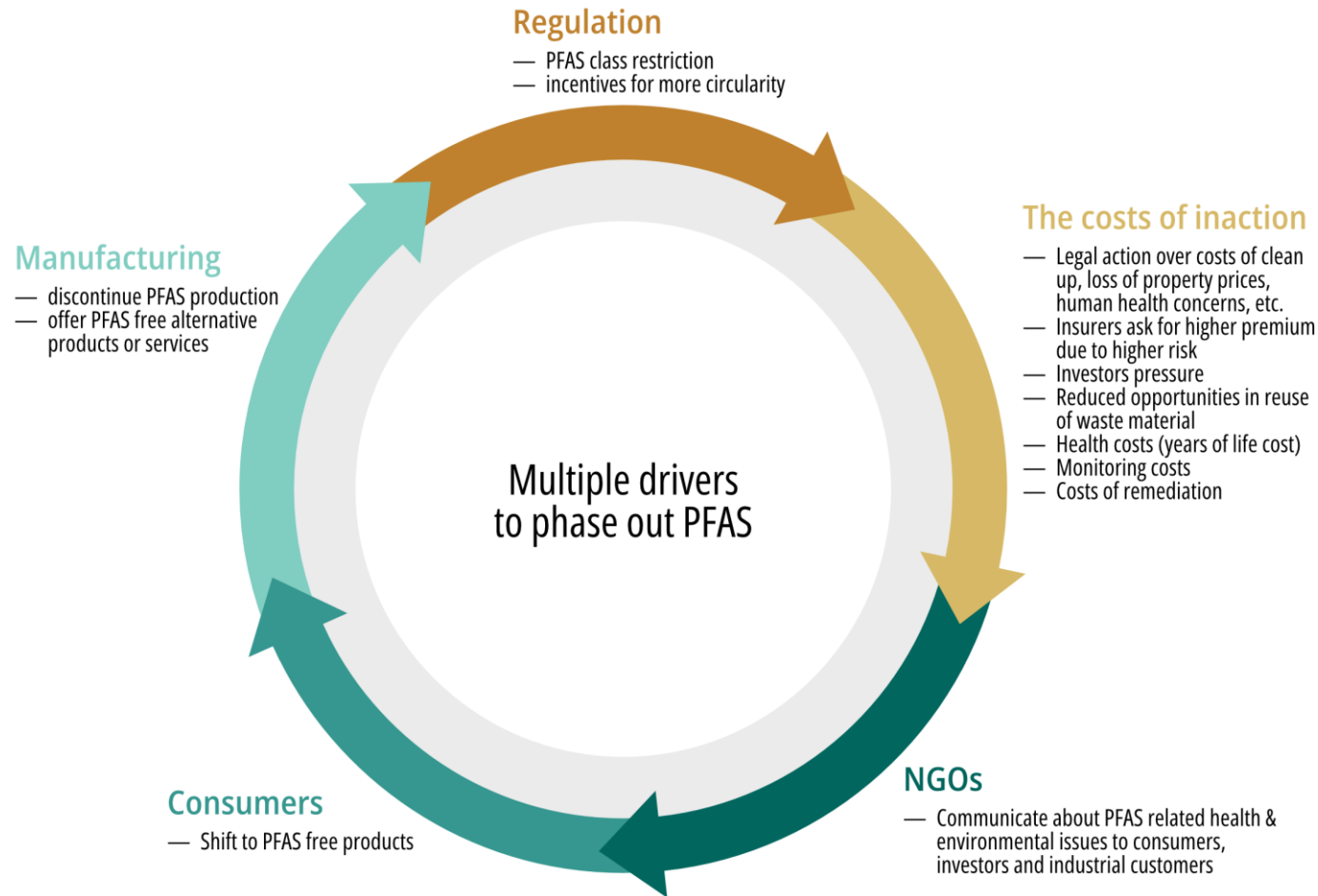

Essentiality

- Impractical to ban all uses of all PFAS in one step
- Can “essentiality” guide substitution?
- Montreal Protocol on Substances that Deplete the Ozone Layer
 - Introduced concept of essential use
 - Adapt the Montreal Protocol’s criteria for essentiality
 - “necessary for health and safety or critical to the functioning of society”

Defining essentiality

Category	Definition
1 “Non-essential”	Uses that are not essential for health and safety, and the functioning of society. The use of substances is driven primarily by market opportunity.
2 “Substitutable”	Uses that have come to be regarded as essential by society because they perform important functions, but where alternatives to the substances have now been developed that have equivalent functionality and adequate performance, which makes those uses of the substances no longer essential.
3 “Essential”	Uses considered essential by society because they are necessary for health or safety or other highly important purposes <i>and</i> for which alternatives are not yet established.*

*This essentiality should not be considered permanent; rather, a constant pressure is needed to search for alternatives in order to move these uses into Category 2 above.

Environmental
Science
Processes & Impacts



CRITICAL REVIEW

[View Article Online](#)
[View Journal](#) | [View Issue](#)



Cite this: *Environ. Sci.: Processes Impacts*, 2019, 21, 1803

The concept of essential use for determining when uses of PFASs can be phased out

Ian T. Cousins,^{a,*} Greta Goldenman,^b Dorte Herzke,^c Rainer Lohmann,^d Mark Miller,^e Carla A. Ng,^f Sharyle Patton,^g Martin Scheringer,^h Xenia Trier,ⁱ Lena Vierke,^j Zhanyun Wang,^k and Jamie C. DeWitt^l

Applied the
concept to multiple
cases studies for
use cases of PFAS

It's all about function

- What is the function of the chemical of concern?
- Different aspects of function (“functional substitution”)
 - Chemical function, end-use function and service function (from “functional substitution”)
- Function of PFAS in aqueous-film forming foams (AFFF)
 - chemical function = powerful surfactant, inert (persistent!)
 - end-use function = to facilitate the spreading of an aqueous film that rapidly spreads over the fuel and flames
 - service function = to rapidly extinguish a fuel fire

Opportunities for substitution

Table 1. Functional Substitution for Chemicals in Products, Chemicals in Processes

Functional Substitution Level	Chemical in Product Bisphenol-a in Thermal Paper	Chemical in Process Methylene Chloride in Degreasing Metal Parts
Chemical Function (Chemical Change)	Is there a functionally equivalent chemical substitute (i.e., chemical developer)? Result: Drop-in chemical replacement	Is there a functionally equivalent chemical substitute (i.e., chlorinated solvent degreaser)? Result: Drop-in chemical replacement
End Use Function (Material, Product, Process Change)	Is there another means to achieve the function of the chemical in the product (i.e., creation of printed image)? Result: Redesign of thermal paper, material changes	Is there another means to achieve the function of the process (i.e., degreasing)? Result: Redesign of the process (e.g., ultrasonic, aqueous)
Function As Service (System Change)	Are cash register receipts necessary? Are there alternatives that could achieve the same purpose (i.e. providing a record of sale to a consumer)? Result: Alternative printing systems (e.g., electronic receipts)	Is degreasing metal parts necessary? Are there other alternatives that could achieve the same purpose (i.e., providing metal parts free of contaminants for other end uses)? Result: Alternative metal cutting methods

Aspects to consider

- Aspect 1: Is the functional use necessary for its performance in the application?
 - Aspect 2: Is the use necessary for health and safety and critical for the functioning of society?
 - Aspect 3: Are there no available alternatives for this particular use that are acceptable from the viewpoint of health safety, etc.?
-
- If all aspects true then **essential use**
 - If one false then **non-essential use**



Combining functional substitution and the essential-use concept

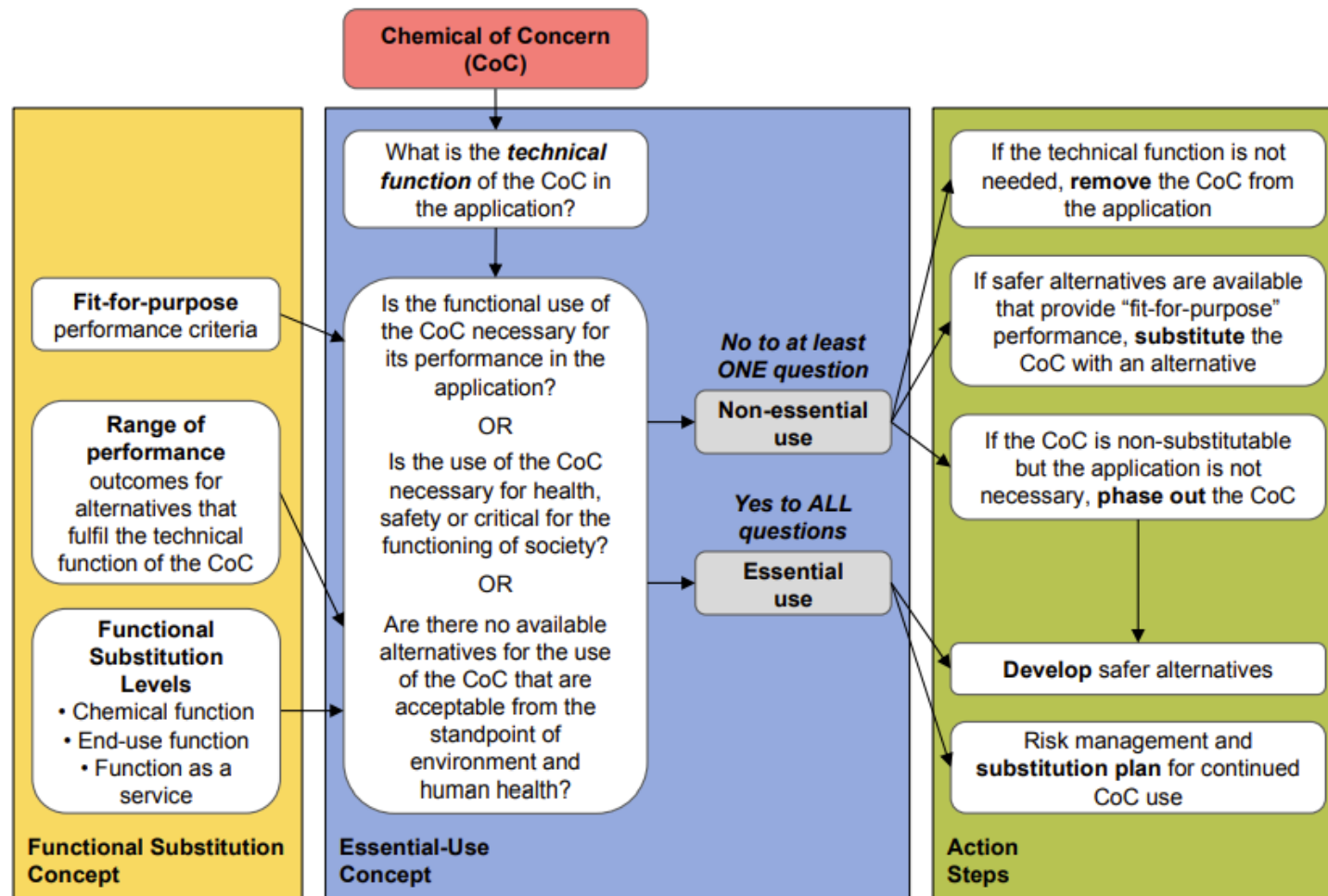

Currently Unavoidable Uses (CUUs)

- Maine and Minnesota set March 1 2024 for comments and submissions related to identification of currently unavoidable uses (CUUs) of PFAS in products.
 - Maine's PFAS in Products law, 38 M.R.S. § 1614
 - PFAS in Products law, Minn. Stat. § 116.943
- Ultimately, the goal of the CUU process will be securing exemption from upcoming restrictions on products which contain PFAS.
 - Public participation in these processes
 - Maine and Minnesota are cooperating in the processes



Three example case studies for uses of PFAS



Ski waxes

- Fluorinated waxes are favored by competitive skiers
- Waxes contain fluorinated alkanes, but also perfluoroalkyl carboxylates, including PFOA
- Don't need to ski e.g. 5% faster. Alternatives "fit for purpose"



FIS ban on fluorinated ski waxes in place since 2020/21 season

Delay due to lack of testing methods

Skis tested for F-content in less than one minute using FT-IR spectroscopy

AFFFs (aqueous film-forming foams)

- Extinguishing class B fuel fires
- Fluorine-free class B foams (3F) available since early 2000s
 - meet the standard firefighting performance certifications
 - use different end-use function than AFFFs
 - many commercial airports have phased out AFFFs and use 3F
- Still some debate if 3F suitable for certain scenarios
 - Are they “fit for purpose”?



Repellency in textiles

Highly fluorinated chemicals in functional textiles can be replaced by re-evaluating liquid repellency and end-user requirements

Steffen Schellenberger ^{a,1}, Philippa J. Hill ^{b,1}, Oscar Levenstam ^c, Philip Gillgard ^d, Ian T. Cousins ^{a,*}, Mark Taylor ^b, Richard S. Blackburn ^{b, **}

Repellency to a wide range of polarities needed in some cases

But do we need stain-proof ties?

PFAS still used in high performance outdoor clothing

Alternatives for durable water repellency (DWR) in everyday outdoor clothing and leisure wear

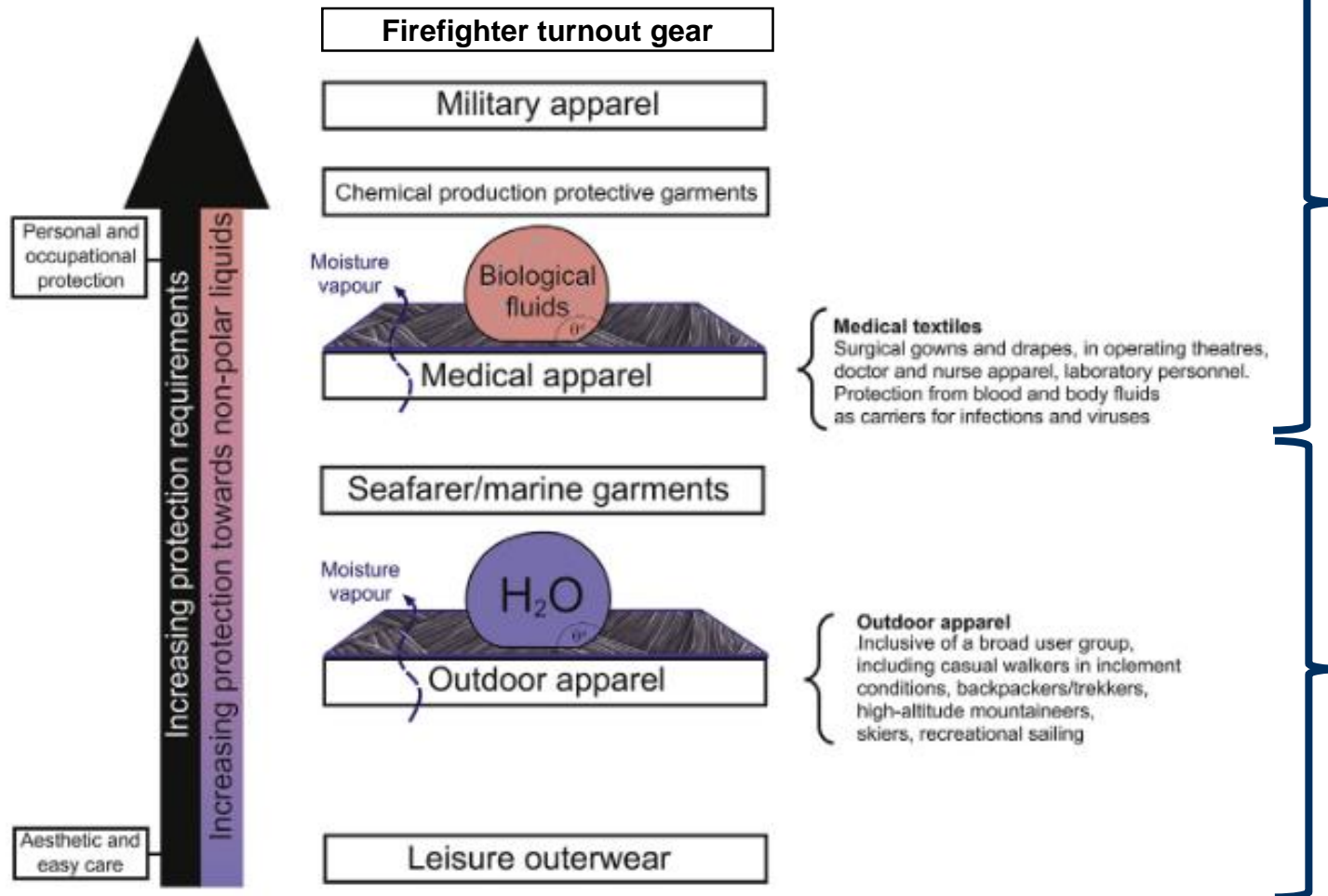

Challenges for applying essentiality

- Substitutable uses
 - avoid regrettable substitutions: alternatives assessment
- How to decide when uses are “essential” or “non-essential”?
 - in many use cases there are alternatives
 - but when there are no alternatives who decides what is necessary for health and safety and critical for the functioning of society?
 - role of multiple stakeholders, social science?



PFAS alternatives database

- Database divided per use category of PFAS
- For each use category:
 - List of applications of PFAS along with the chemical function, end use function and service function
 - List of PFAS substances identified as being used for each application
 - List of identified potential alternatives to PFAS for each application

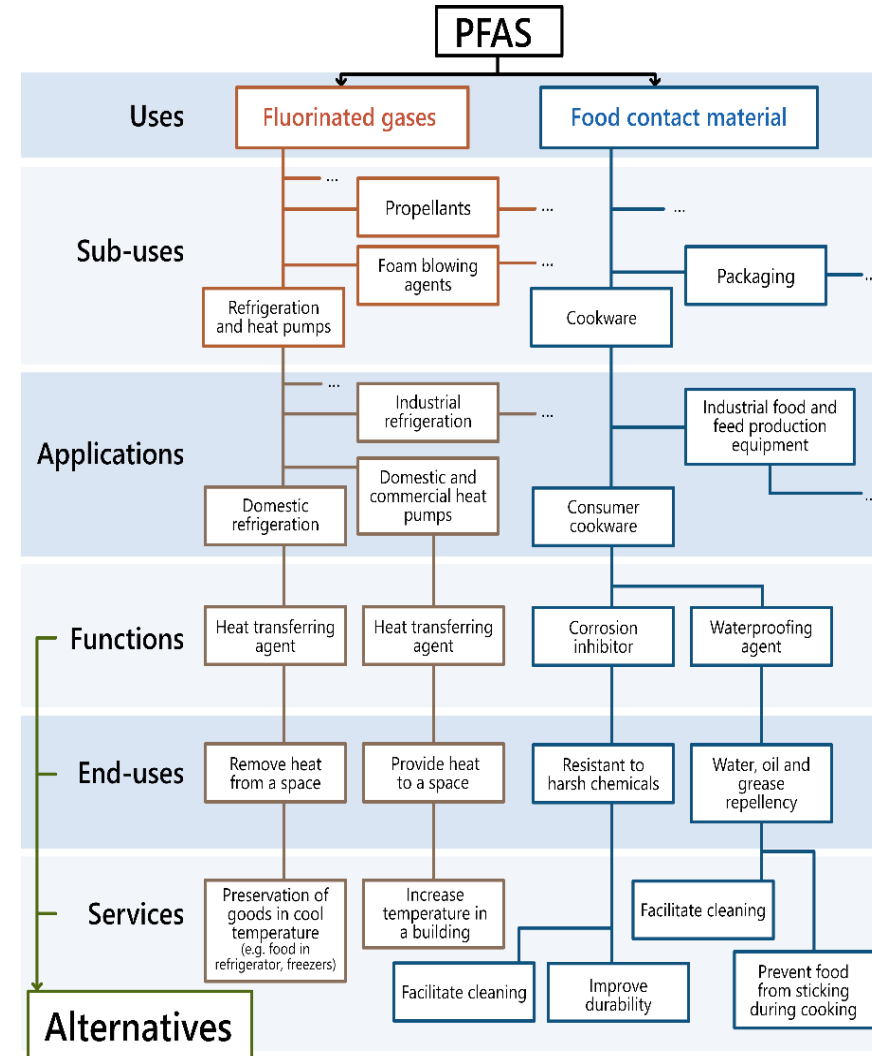

Important sources of information

EUROPEAN CHEMICALS AGENCY

ANNEX XV RESTRICTION REPORT

PROPOSAL FOR A RESTRICTION

SUBSTANCE NAME(S): Per- and polyfluoroalkyl substances (PFASs)
IUPAC NAME(S): n.a.
EC NUMBER(S): n.a.
CAS NUMBER(S): n.a.

CONTACT DETAILS OF THE DOSSIER SUBMITTERS:

BAuA
Federal Institute for Occupational Safety and Health
Division 5 - Federal Office for Chemicals
Friedrich-Henkel-Weg 1-25
D-44149 Dortmund, Germany

Bureau REACH, National Institute for Public Health and the Environment (RIVM)
Antonie van Leeuwenhoeklaan 9
3721 MA Bilthoven, The Netherlands

Swedish Chemicals Agency (KEMI)
PO Box 2,
SE-172 13 Sundbyberg, Sweden

Norwegian Environment Agency
P.O. Box 5672 Torgarden
N-7485 Trondheim, Norway

The Danish Environmental Protection Agency
Tolderlundsvej 5
5000 Odense C, Denmark

VERSION NUMBER: 2
DATE: 22.03.2023

Environmental Science Processes & Impacts



PAPER [View Article Online](#)
View Journal | View Issue

 Check for updates

An overview of the uses of per- and polyfluoroalkyl substances (PFAS)†

Cite this: *Environ. Sci.: Processes Impacts*, 2020, 22, 2345

Juliane Glüge,^a Martin Schering,^a Ian T. Cousins,^b Jamie C. DeWitt,^c Gretta Goldenman,^d Dorte Herzke,^{b,e,f} Rainer Lohmann,^{b,g} Carla A. Ng,^{b,h} Xenia Trierⁱ and Zhanyun Wang^j



MARKETPLACE

Uses and functions of PFAS

- 18 use categories of PFAS included in the database
- Waterproofing agent, heat stabilizer and corrosion inhibitor are the most common technical functions
- Mainly for enhancing durability

Use categories	Sub-uses	Applications	Technical functions	End-use functions	Services
Active pharmaceutical ingredients	2	14	1	24	21
Biocides	1	4	1	4	4
Building and construction products	9	17	14	18	30
Consumer mixtures	7	15	7	15	12
Cosmetic products	5	32	9	12	6
Electronics and semiconductors sector	3	29	17	22	37
Energy sector	9	19	17	19	24
Firefighting foams	1	5	1	1	3
Fluorinated gases	7	29	8	14	27
Food contact materials	2	4	4	4	9
Industrial production	8	28	12	18	11
Lubricants	3	42	11	13	19
Medical products	6	21	14	18	29
Metal plating and metal products manufacture	2	4	8	10	14
Petroleum and mining	2	9	10	13	15
Plant Protection Products	1	6	3	7	5
Textile, upholstery, leather, apparel, and carpets	7	20	11	15	21
Transport sector	10	27	16	24	45
Grand Total	85	325	39	131	201

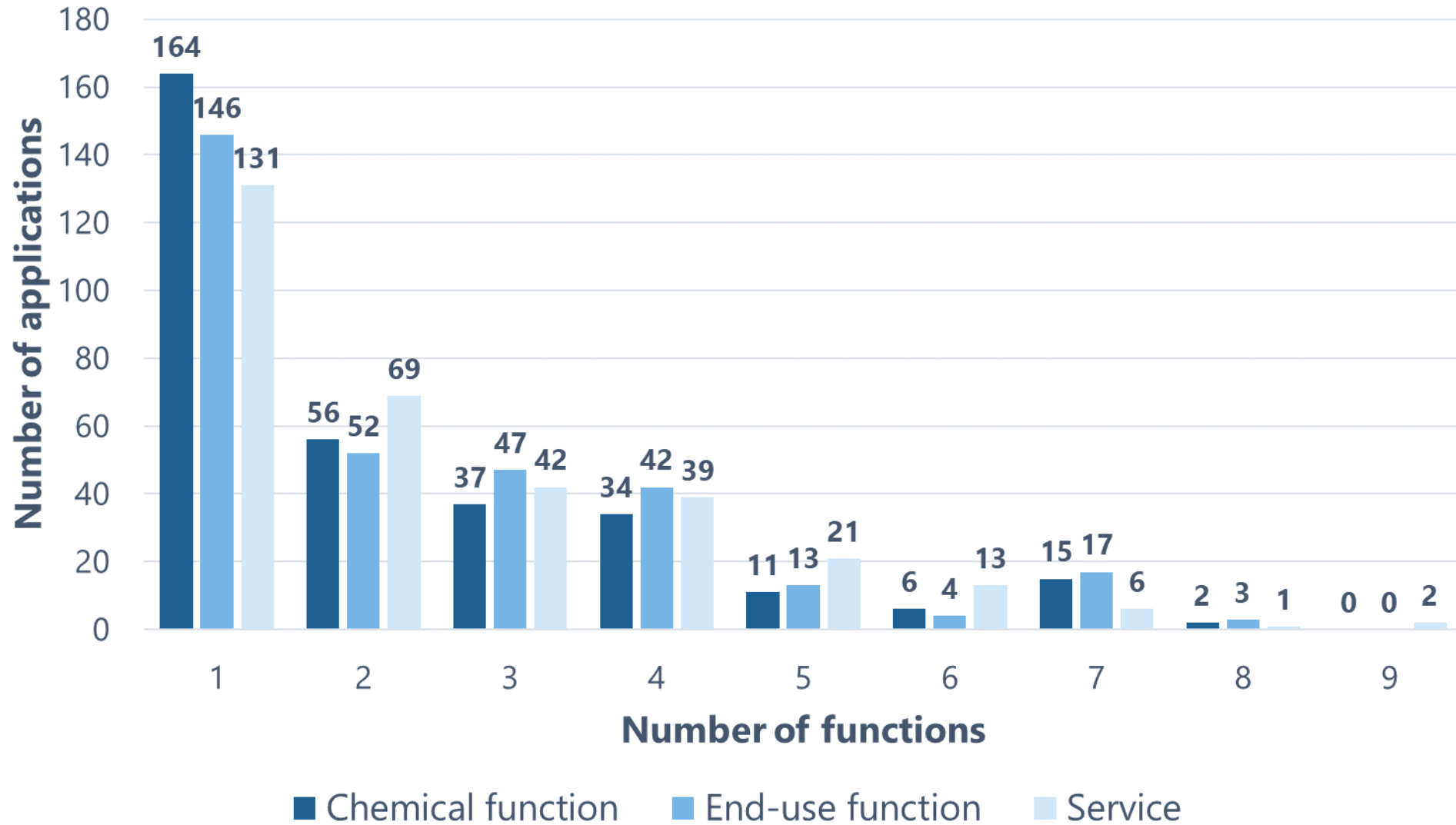
Number of functions provided by PFAS



Information on alternatives

- **Alternative identifiers:** name and CAS number (if relevant)
- **Alternative type:** substance; material; product; process; technology
- **General chemistry:** Organic synthetic; silicone-based; natural-based; inorganic
- **PBT assessment and CLP classification (if available)**
- **Flagged:** whether an alternative is listed in the Substitution Support Portal (https://www.subsportplus.eu/subsportplus/EN/Substances/Database-of-restricted-and-priority-substances/restricted-priority-substances_node.html)
- **Change in functionality and market uptake:** Based on information available in the PFAS restriction

Number and types of alternatives to PFAS

- Database includes 532 different potential alternatives across 14 use categories
 - Left out active pharmaceutical ingredients, cosmetic products, plant protection products and biocides
- No alternative found for 83 applications (mainly for industrial production)

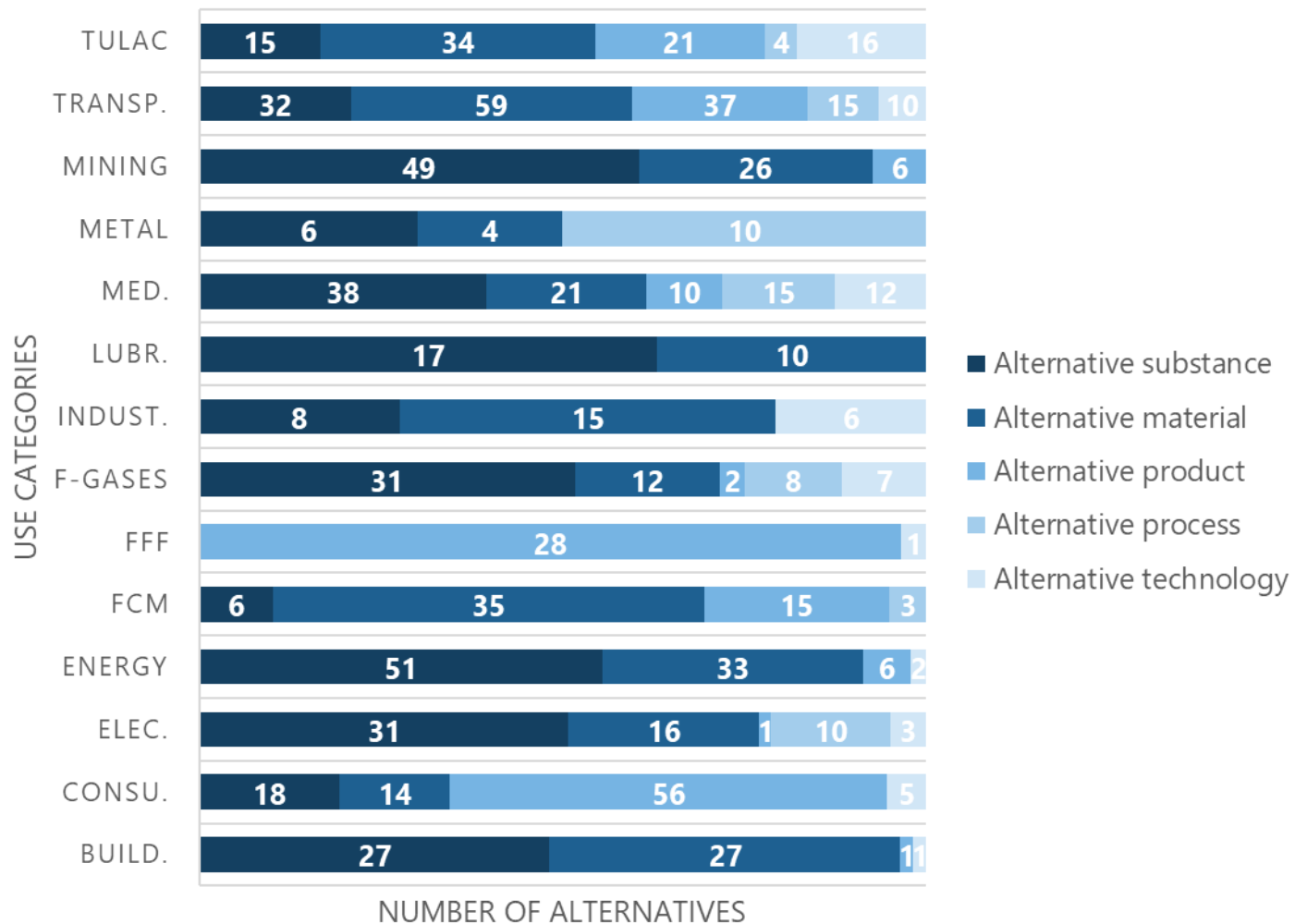

Alternative chemistries

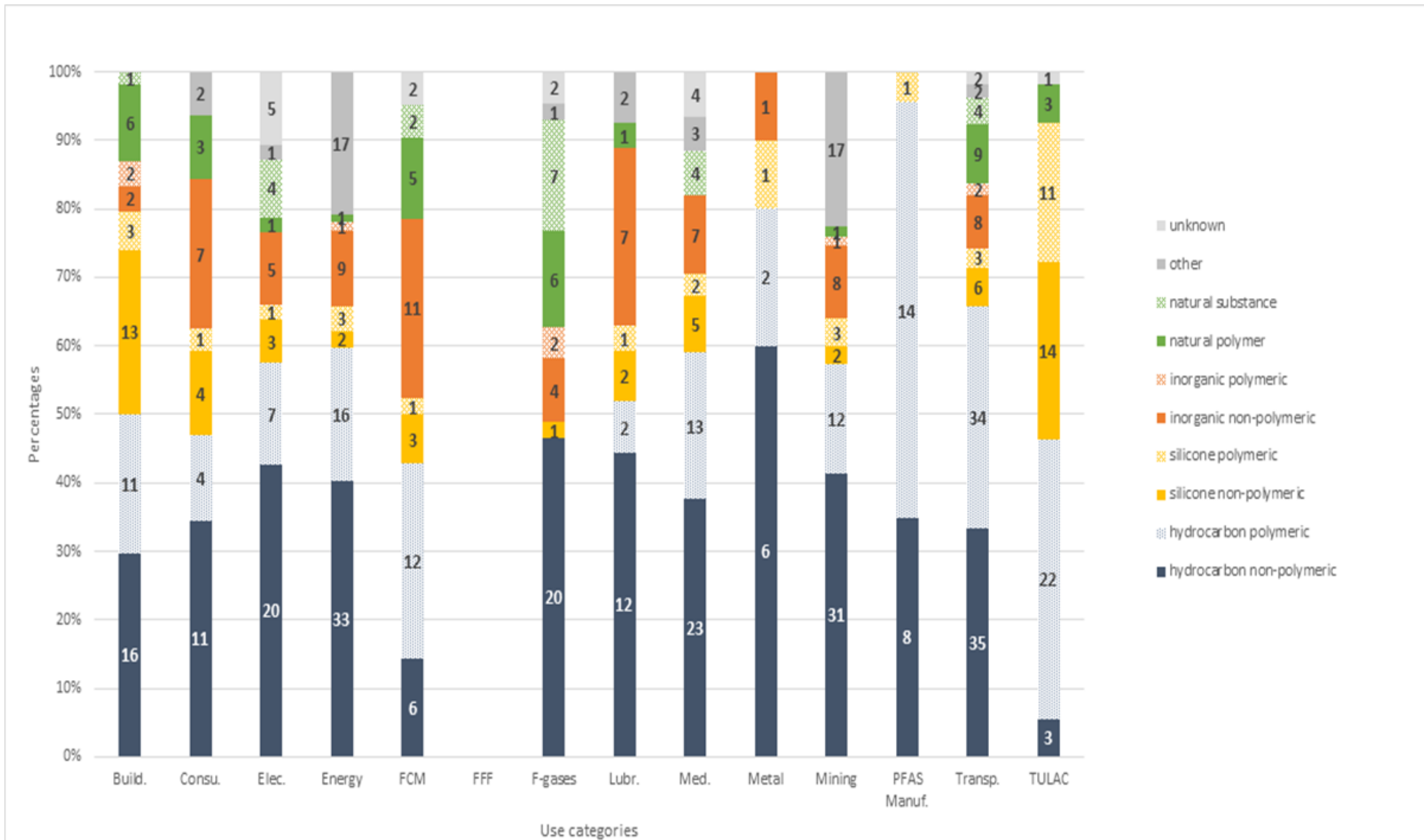

Safety of alternatives to PFAS

- Evaluation based on the Substitution Support Portal (https://www.subsportplus.eu/subsportplus/EN/Home/Home_no_de.html)
- Possible only for alternatives identified by a CAS number (i.e. 36%)

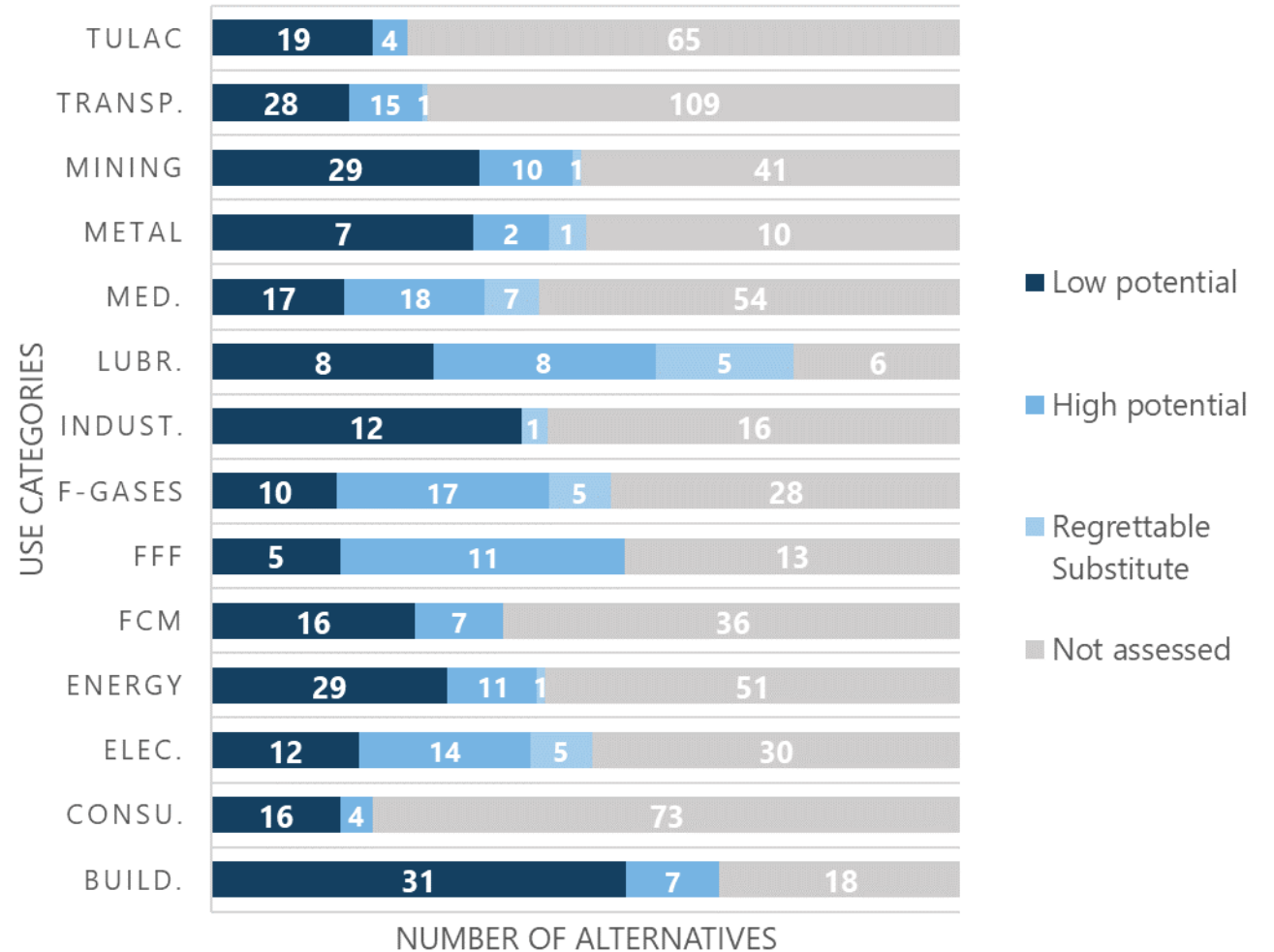

Are the alternatives suitable and available?

- Overall, no suitable alternatives available for ~25% of PFAS applications

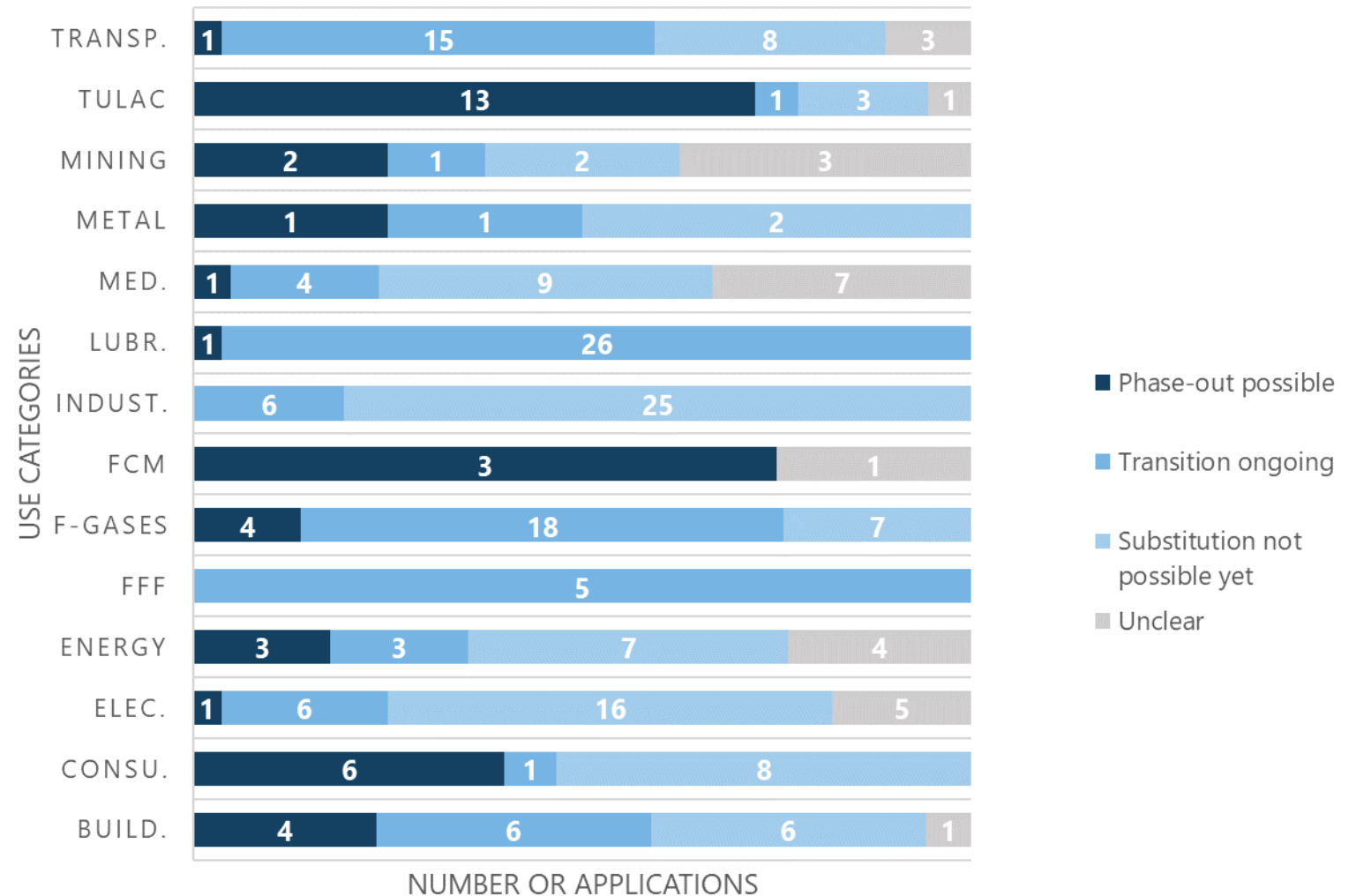

Biggest challenges to universal phase-out

- F-gases
- Industrial uses of fluoropolymers
- Green energy transition
- Medical applications

acea

DRIVING MOBILITY FOR EUROPE

NEWS ▾ FACTS & FIGURES ▾ PUBLICA

Home | News articles | Importance of fluoropolymers for the clean energy transition and the EU's net zero industry

Importance of fluoropolymers for the clean energy transition and the EU's net zero industry



EURACTIV The Capitals The Brief Ukraine Intelligence

Agrifood Economy Energy & Environment Global Europe Health Politics Technology Transport

There is no Green Deal without fluorinated chemistry

DISCLAIMER: All opinions in this column reflect the views of the author(s), not of EURACTIV Media network.

By Gerardo Familiar | Chemours Company | Est. 5min | May 9, 2023

Content-Type: Advertiser Content



Supporters

 Chemours

From Twitter



PLASTICS EUROPE Fluoropolymers Product Group

Fluoropolymers ▾ Irreplaceable uses ▾ EU PFAS restriction ▾ Knowledge center ▾ FAQ ▾ News ▾ About ▾ Contact



The importance of fluoropolymers for the sector

Europe is at the forefront of the development and the use of renewable energy and has one of the most ambitious goals for a sustainable future in this respect. Fluoropolymers are an indispensable driver of the European Green Deal, as they have a key role to play in the transition to an integrated and decarbonized energy system. With their unique combination of properties, fluoropolymers are crucial components in hydrogen

Conclusions/observations

- It's encouraging that so many alternatives to uses of PFAS already available and transitions have occurred or are happening
 - Hard work for product manufacturers and retailers
- Challenges remain but shift happens!
 - Unique properties of PFAS offering multiple functions
 - Some applications with no available alternatives currently available
 - Ensuring no regrettable substitutions (alternatives assessment)
 - Resistance from some industries
- Green energy transition being used as a “free pass” for derogations
- Strong PFAS regulation, and other drivers, encourage innovation

For more information



Email:

romain.figuier@aces.su.se

**Access to the alternatives
database**

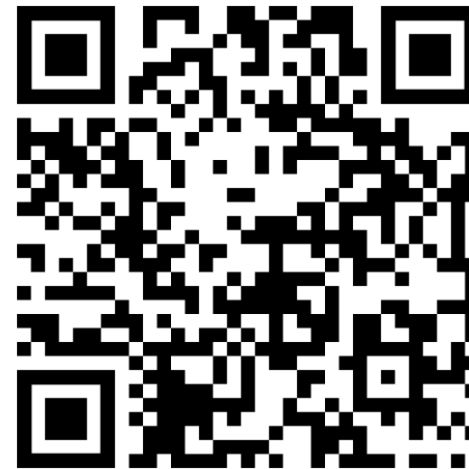

Acknowledgments

Thanks to the ZeroPM project for supporting work on the essential use concept and alternative assessment. Thanks to my colleagues and coauthors, Romain Figuière, Eleni Savvidou and Luc Miaz.



This project has received funding from the European Union's Horizon 2020 research and innovation programme under grant agreement No 101036756.

